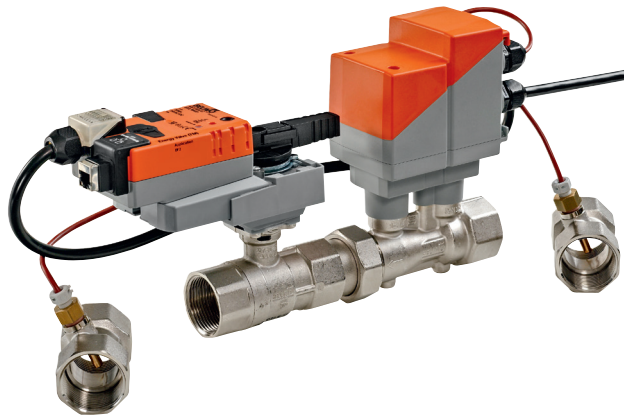

Characterised control valve (CCV) with sensor-operated flow rate or power control, power and energy-monitoring function, 2-way, internal thread

- Nominal voltage AC/DC 24 V
- Control modulating
- For closed cold and hot water systems
- For modulating water-side control of air handling systems and heating systems
- Ethernet 10/100 Mbit/s, TCP/IP, integrated web server
- Communication via BACnet IP, BACnet MS/TP, Belimo MP-Bus or conventional control

Type overview

Type	Vnom [l/s]	Vnom [l/min]	kvs theor. [m ³ /h]	DN []	Rp ["]	ps [kPa]	n(gl) []
EV015R+BAC	0.35	21	2.9	15	1/2	1600	3.2
EV020R+BAC	0.65	39	4.9	20	3/4	1600	3.2
EV025R+BAC	1.15	69	8.6	25	1	1600	3.2
EV032R+BAC	1.8	108	14.2	32	1 1/4	1600	3.2
EV040R+BAC	2.5	150	21.3	40	1 1/2	1600	3.2
EV050R+BAC	4.8	288	32.0	50	2	1600	3.2

kvs theor.: Theoretical kvs value for pressure drop calculation

Technical data

Electrical data	Nominal voltage	AC/DC 24 V
	Nominal voltage frequency	50/60 Hz
	Nominal voltage range	AC 19.2...28.8 V / DC 21.6...28.8 V
	Power consumption in operation	DN 15...25 4 W / DN 32...50 5 W
	Power consumption in rest position	DN 15...25 3.7 W / DN 32...50 3.9 W
	Power consumption for wire sizing	DN 15...25 6.5 VA / VA 32...50 7.5 VA
	Connection supply / control	Cable 1 m, 6 x 0.75 mm ²
	Connection control Ethernet	RJ45 socket
Parallel operation	Yes (note the performance data)	
Functional data	Torque motor	5 Nm (DN 15...25) / 10 Nm (DN 32 + 40) / 20 Nm (DN 50)
	Communicative control	BACnet Application Specific Controller (B-ASC) BACnet IP, BACnet MS/TP (for details, see separate document "PICS") MP bus (for details, see separate document "Data-Pool Values")
	Positioning signal Y	DC 0...10 V
	Operating range Y	DC 0.5...10 V
	Operating range Y variable	DC 2...10 V
	Position feedback U	DC 0.5...10 V
	Position feedback U variable	DC 0...10 V DC 2...10 V
	Sound power level motor max.	45 dB(A)
	Adjustable flow rate Vmax	30...100% of Vnom
	Control accuracy	±10% (of 25...100% Vnom)
	Control accuracy note	±6% (of 25...100% Vnom) at 20 °C / Glycol 0% vol.
	Configuration	via integrated web server / ZTH EU
	Media	Cold and hot water, water with glycol up to max. 50% vol.
	Medium temperature	-10 °C...120 °C
Closing pressure Δps	1400 kPa	
Differential pressure Δpmax	350 kPa	
Differential pressure note	200 kPa for low-noise operation	

Technical data

Functional data	Flow characteristic	Equal percentage (VDI/VDE 2178), optimised in the opening range (can be switched to linear)
	Leakage rate	Air bubble-tight (Leakage rate A, EN12266-1)
	Pipe connections	Internal thread in accordance with ISO 7-1
	Installation position	Upright to horizontal (in relation to the stem)
	Maintenance	Maintenance-free
	Manual override	Gear disengagement with push-button, can be locked
Flow measurement	Measuring principle	Ultrasonic volumetric flow measurement
	Measuring accuracy	±6% (of 25...100% \dot{V}_{nom})
	Measuring accuracy note	±2% (of 25...100% \dot{V}_{nom}) at 20°C / Glycol 0% vol.
	Min. flow measurement	1% of \dot{V}_{nom}
Temperature measurement	Measuring accuracy of the absolute temperature	± 0.6°C @ 60°C (PT1000 EN60751 Class B)
	Measuring accuracy of temperature difference	±0.23 K @ $\Delta T = 20$ K
	Resolution	0.05°C
	Safety	Protection class IEC/EN
Degree of protection IEC/EN		IP54 (for use of protective cap or grommet for RJ45 socket)
EMC		CE according to 2004/108/EC
Materials	Mode of operation	Type 1
	Rated impulse voltage supply / control	0.8 kV
	Control pollution degree	3
	Ambient temperature	-30...50°C
	Non-operating temperature	-40...80°C
	Ambient humidity	95% r.h., non-condensing
	Housing	Brass body
	Measuring pipe	Brass body nickel-plated
	Valve cone	Stainless steel
	Stem	Stainless steel
Stem seal	O-ring EPDM	
Immersion sleeve	Stainless steel AISI 316Ti	
T-Piece	Brass body nickel-plated	

Safety notes



- This device has been designed for use in stationary heating, ventilation and air conditioning systems and is not allowed to be used outside the specified field of application, especially in aircraft or in any other airborne means of transport.
- Only authorised specialists may carry out installation. All applicable legal or institutional installation regulations must be complied with during installation.
- The connection between the control valve and the measuring tube should not be separated.
- The device contains electrical and electronic components and is not allowed to be disposed of as household refuse. All locally valid regulations and requirements must be observed.

Product features

Mode of operation The actuator is comprised of four components: characterised control valve (CCV), measuring pipe with volumetric flow sensor, temperature sensors and the actuator itself. The adjusted maximum flow (\dot{V}_{max}) is assigned to the maximum positioning signal (typically 10 V / 100%). Alternatively, the positioning signal can be assigned to the valve opening angle or to the power required on the heat exchanger (see power control).

The actuator control can be either communicative or analogue. The medium is detected by the sensor in the measuring pipe and is applied as the flow value. The measured value is balanced with the setpoint. The actuator corrects the deviation by changing the valve position. The angle of rotation α varies according to the differential pressure through the final controlling element (see volumetric flow curves).

Flow rate curves

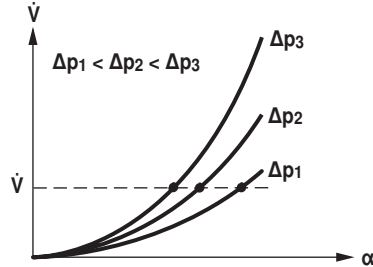

Flow characteristic of the characterised control valve

Heat exchanger transfer response

Depending on the construction, temperature spread, medium and hydraulic circuit, the power Q is not proportional to the volumetric flow of the water \dot{V} (curve 1). With the classical type of temperature control, an attempt is made to maintain the control signal Y proportional to the power Q (curve 2). This is achieved by means of an equal-percentage valve characteristic curve (curve 3).

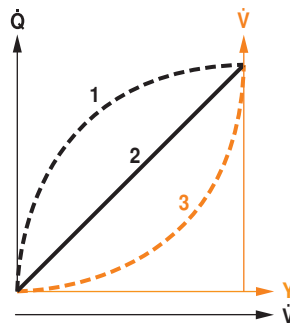

Power control

Alternatively, the positioning signal Y can be assigned to the output power required on the heat exchanger.

Depending on the water temperature and air conditions, the Energy Valve ensures the amount of water required \dot{V} to achieve the desired power.

Maximum controllable power on heat exchanger in power control mode:

DN 15	30 kW
DN 20	60 kW
DN 25	100 kW
DN 32	160 kW
DN 40	210 kW
DN 50	410 kW

Control characteristics

The specially configured control parameters in connection with the precise flow rate sensor ensure a stable quality of control. They are however not suitable for rapid control processes, i.e. for domestic water control.

Product features

Definition of flow rate \dot{V}_{nom} is the maximum possible flow.

\dot{V}_{max} is the maximum flow rate which has been set with the greatest positioning signal, e.g. 10 V. \dot{V}_{max} can be set to between 30% and 100% of \dot{V}_{nom} .

\dot{V}_{min} 0% (non-variable).

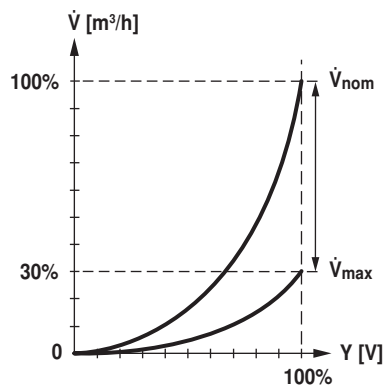

Performance definition \dot{Q}_{max} is the set maximum power output on the heat exchanger (in power control operating mode)

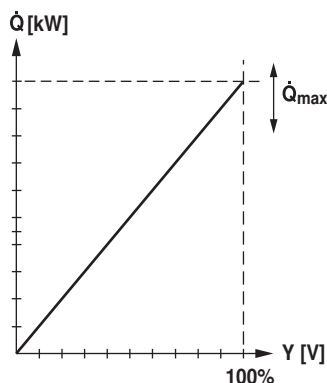

Creep flow suppression Given the very low flow speed in the opening point, this can no longer be measured by the sensor within the required tolerance. This range is overridden electronically.

Opening valve

The valve remains closed until the volumetric flow required by the positioning signal Y corresponds to 1% of \dot{V}_{nom} . The control along the valve characteristic curve is active after this value has been exceeded.

Closing valve

The control along the valve characteristic curve is active up to the required flow rate of 1% of \dot{V}_{nom} . Once the level falls below this value, the flow rate is maintained at 1% of \dot{V}_{nom} . If the level falls below the flow rate of 0.5% of \dot{V}_{nom} required by the reference variable Y, then the valve will close.

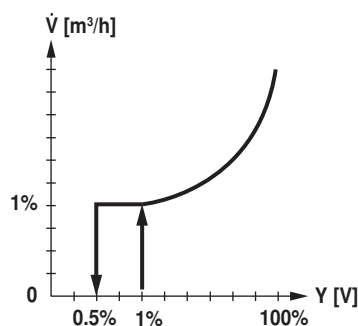

Product features

Communication The parameterisation can be carried out through the integrated web server (RJ45 connection to the web browser) or by communicative means. Additional information regarding the integrated web server can be found in the separate documentation.

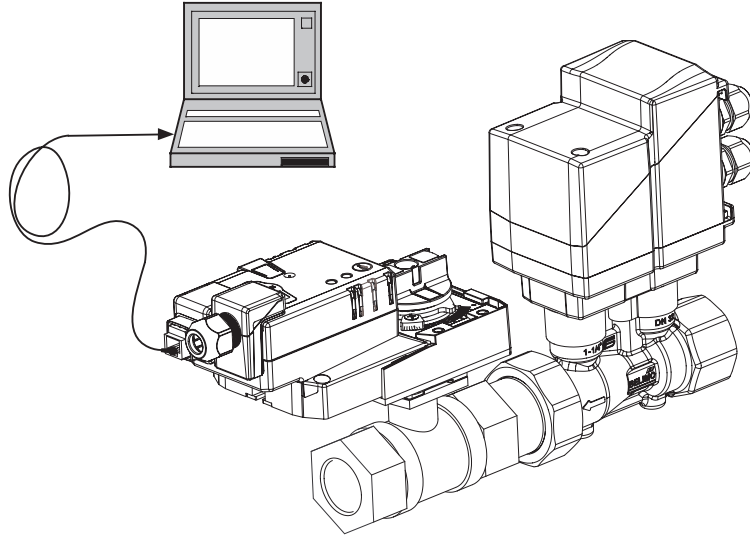
**"Peer to Peer" connection**

<http://belimo.local:8080>

The Notebook must be set to "DHCP".
Make sure that only one network connection is active.

Standard IP address:

<http://192.168.0.10:8080>

Static IP address

Password (read-only):

User name: "guest"

Password: "guest"

Positioning signal inversion

This can be inverted in cases of control with an analogue positioning signal. The inversion causes the reversal of the standard behaviour, i.e. at a positioning signal of 0%, regulation is to \dot{V}_{max} or Q_{max} , and the valve is closed at a positioning signal of 100%.

Hydraulic balancing

Via the integrated web server, the maximum flow rate (equivalent to 100% requirement) can be adjusted directly on the device itself, simply and reliably, in a few steps. If the device is integrated in the management system, then the balancing can be handled directly by the management system.

Delta-T manager

If a heating or cooling register is operated with a differential temperature that is too low and thus with a flow rate that is too high, this will not result in an increased power output. Nevertheless, heating or cooling machines must provide the energy at a lower degree of effectiveness. Pumps circulate too much water and increase energy consumption unnecessarily. With the aid of the Energy Valve, it is simple to discover that operation is being carried out at a differential temperature that is too low, resulting in the inefficient use of energy. Necessary setting adjustments can now be carried out quickly and easily at any time. The integrated differential temperature control offers the user in addition the possibility of defining a low limit value. The Energy Valve limits the flow rate automatically to prevent the level from falling below this value.

Power output of the heating or cooling registers 1
Differential temperature between supply and return 2
Loss zone (heating or cooling register saturation) 3
Adjustable minimum differential temperature 4

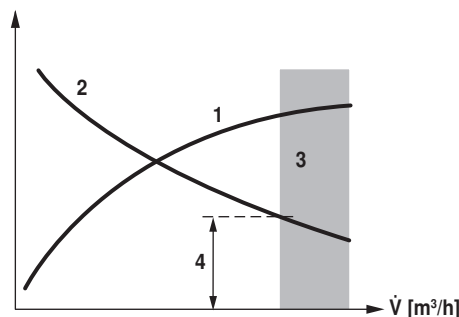

Product features

Combination analogue - communicative	<p>The integrated web server, BACnet IP, BACnet MS/TP or MP bus can be used for the communicative position feedback with conventional control by means of an analogue positioning signal.</p> <p>When the combination of positioning signal Y and communicative position feedback is used, it is imperative to ensure that the communicative path is used solely for data transfer from the Energy Valve to the higher-level management system. If values are transferred communicatively via bus to the Energy Valve, then the analogue control will be automatically deactivated.</p> <p>This deactivation can be reversed by disconnecting the Energy Valve from the power supply.</p>
Power and energy monitoring function	<p>The actuator is equipped with two temperature sensors. A sensor (T2) must be installed at the valve and the second sensor (T1) must be installed on-site on the other side of the water circulation. The two sensors are enclosed with the system already wired. The sensors are used to record the medium temperature of the supply and return lines of the consumer (heat/cold register). As the water quantity is also known, thanks to the volumetric flow measurement integrated in the system, the power released from the consumer can be calculated. Furthermore, the heating/cooling energy is also determined automatically by means of the evaluation of the power over time.</p> <p>The current data, e.g. temperatures, volumetric flow volumes, exchanger energy consumption, etc. can be recorded and accessed at any time by means of web browsers or communication (BACnet or MP bus).</p>
Data recording	<p>The recorded data (integrated data recording for 13 months) can be used for the optimisation of the overall system and for the determination of the performance of the consumer.</p> <p>Download csv files through web browser.</p>
Manual override	<p>Manual override with push-button possible (the gear is disengaged for as long as the button is pressed or remains locked).</p>
High functional reliability	<p>The actuator is overload protected, requires no limit switches and automatically stops when the end stop is reached.</p>
Home position	<p>The actuator moves to the home position when the supply voltage is switched on for the first time, i.e. at the time of commissioning or after pressing the "gear disengagement" key.</p> <p>The actuator then moves into the required position in order to ensure the flow rate defined by the positioning signal.</p>

Accessories

	Description	Type
Service Tools	Service tool, for MF/MP/Modbus/LonWorks actuators and VAV controller	ZTH EU

Electrical installation



Notes

- Connection via safety isolating transformer.
- Parallel connection of other actuators possible. Observe the performance data.

Wiring diagrams

BACnet IP

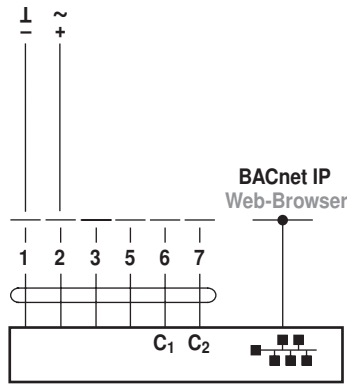

- Cable colours:**
 1 = black
 2 = red
 3 = white
 5 = orange
 6 = pink
 7 = grey

BACnet MS/TP

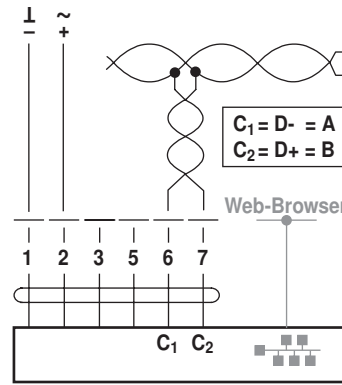

- Cable colours:**
 1 = black
 2 = red
 3 = white
 5 = orange
 6 = pink
 7 = grey

MP bus

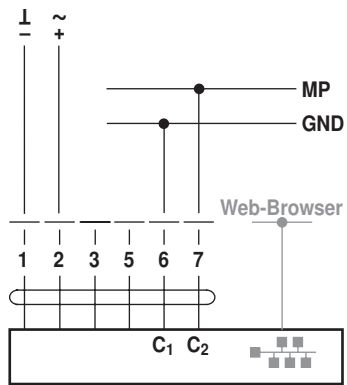

- Cable colours:**
 1 = black
 2 = red
 3 = white
 5 = orange
 6 = pink
 7 = grey

Conventional operation

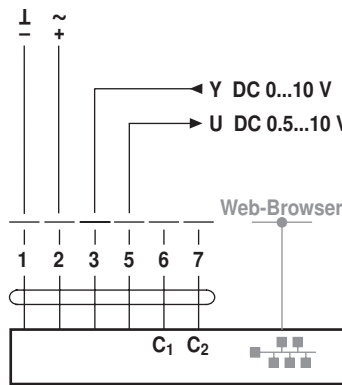

- Cable colours:**
 1 = black
 2 = red
 3 = white
 5 = orange
 6 = pink
 7 = grey



Connection of a notebook for parameterisation and manual control via RJ45.

Optional connection via RJ45 (direct connection Notebook / connection via Intranet or Internet) for access to the integrated webserver

Functions

Functions for actuators with specific parameters

Override control and limiting with DC 24 V with relay contacts

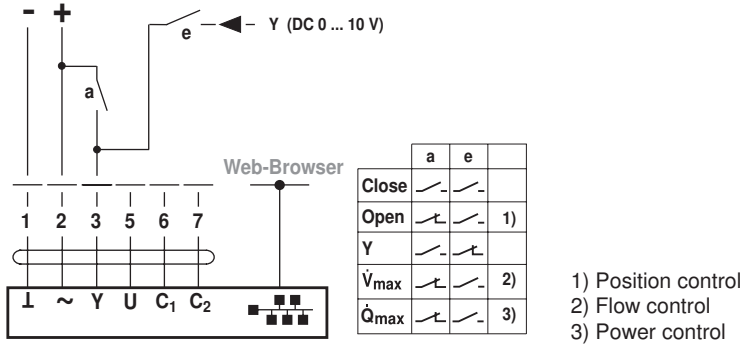

Display and operating elements

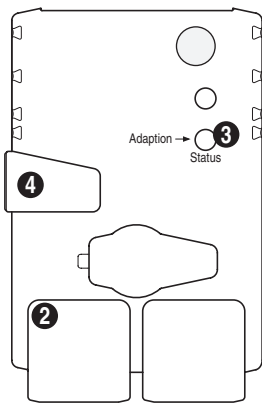

(2) LED display green

Off: No supply or wiring error
Illuminated: Operation
Flickering: Internal communication valve (valve / sensor)

(3) Push-button and LED display yellow

Illuminated: Adaptation procedure active
Press button: Triggers angle of rotation adaptation, followed by standard mode

(4) Gear disengagement button

Press button: Gear disengages, motor stops, manual override possible
Release button: Gear engages, followed by standard mode

Installation notes

Recommended installation positions

The ball valve can be installed upright to horizontal. The ball valve may not be installed in a hanging position, i.e. with the stem pointing downwards.

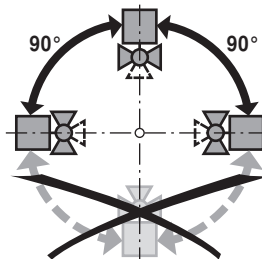

Installation position in return

Installation in the return is recommended.

Water quality requirements

The water quality requirements specified in VDI 2035 must be adhered to. Belimo valves are regulating devices. In order for these control tasks to be able to be carried out in the long run as well, they are to be kept free of solid particles (e.g. welding beads during installation work). The installation of correspondingly sufficient dirt catchers is recommended.

Installation notes

Maintenance Ball valves, rotary actuators and sensors are maintenance-free.

Before any kind of service work is carried out on the actuator, it is essential to isolate the rotary actuator from the power supply (by disconnecting the electrical cable). Any pumps in the part of the piping system concerned must also be switched off and the appropriate slide valves closed (allow everything to cool down first if necessary and reduce the system pressure to ambient pressure level).

The system must not be returned to service until the ball valve and the rotary actuator have been properly reassembled in accordance with the instructions and the pipelines have been refilled in the proper manner.

Flow direction The direction of flow, specified by an arrow on the housing, is to be complied with, since otherwise the flow rate will be measured incorrectly.

Inlet section In order to achieve the specified measuring accuracy, a flow-calming section or inflow section in the direction of the flow is to be provided upstream from the measuring pipe flange. Its dimensions should be at least 5x DN.

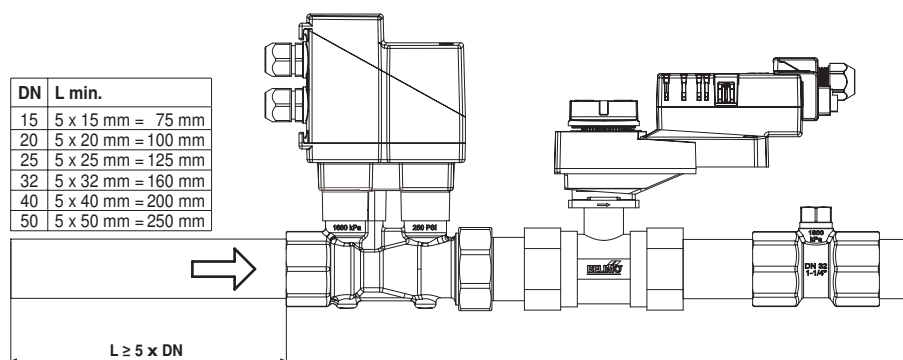

Installation of immersion sleeve and temperature sensor

The valve is equipped with two fully-wired temperature sensors.

- T2: This sensor is installed on site near the valve unit.
- T1: This sensor is mounted at the installation site ahead of the consumer (valve in the return line) or after the consumer (valve in the supply line).

Two T-pieces for installation of the temperature sensors in the pipelines are included in the shipment.

Note

The cables between valve unit and temperature sensors may not be either shortened or lengthened.

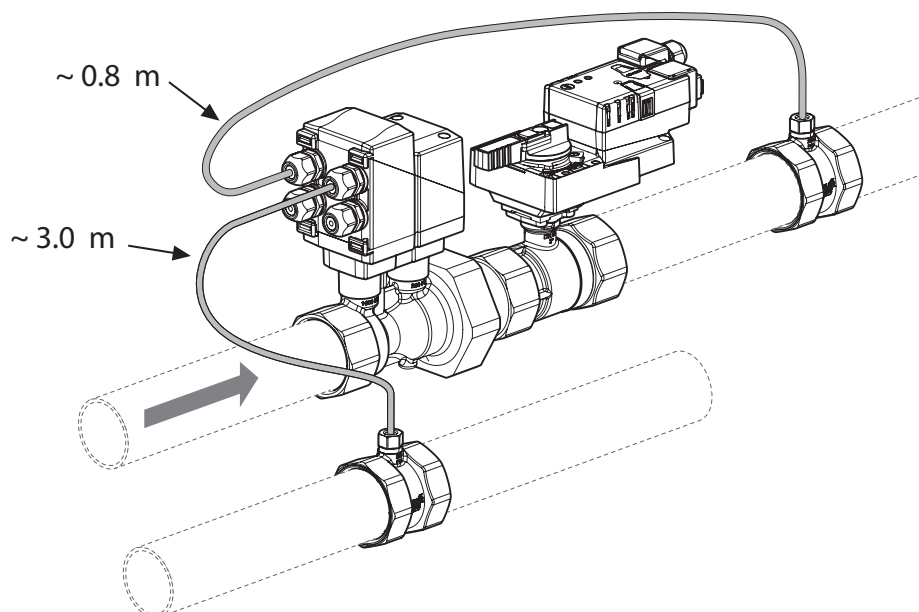

General information

Valve selection The valve is determined using the maximum flow required \dot{V}_{max} . No calculation of the kvs value is required.
 $\dot{V}_{max} = 30 \dots 100\%$ of \dot{V}_{nom}
 If no hydraulic data are available, then the same valve DN can be selected as the heat exchanger nominal diameter.

Minimum differential pressure (pressure drop) The minimum required differential pressure (pressure drop through the valve) for achieving the desired volumetric flow \dot{V}_{max} can be calculated with the aid of the theoretical kvs value (see type overview) and the below-mentioned formula. The calculated value is dependent on the required maximum volumetric flow \dot{V}_{max} . Higher differential pressures are compensated for automatically by the valve.

Formula

$$\Delta p_{min} = 100 \times \left(\frac{\dot{V}_{max}}{k_{vs \text{ theor.}}} \right)^2$$

$\Delta p_{min}: \text{kPa}$
 $\dot{V}_{max}: \text{m}^3/\text{h}$
 $k_{vs \text{ theor.}}: \text{m}^3/\text{h}$

Example (DN25 with the desired maximum flow rate = 50% \dot{V}_{nom})

EV025R+BAC
 kvs theor. = 8.6 m³/h
 $\dot{V}_{nom} = 69 \text{ l/min}$
 50% * 69 l/min = 34.5 l/min = 2.07 m³/h

$$\Delta p_{min} = 100 \times \left(\frac{\dot{V}_{max}}{k_{vs \text{ theor.}}} \right)^2 = 100 \times \left(\frac{2.07 \text{ m}^3/\text{h}}{8.6 \text{ m}^3/\text{h}} \right)^2 = 6 \text{ kPa}$$

Dimensions [mm] / weight

Dimensional drawings

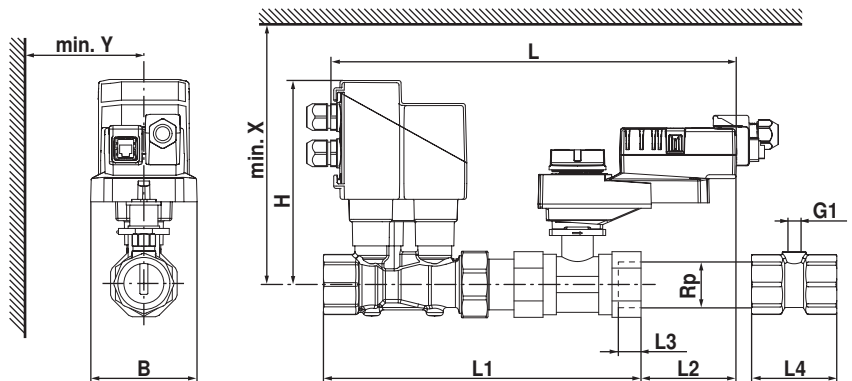

Type	DN []	Rp ["]	L [mm]	L1 [mm]	L2 [mm]	L3 [mm]	B [mm]	H [mm]	G1	L4 [mm]	X [mm]	Y [mm]	Weight approx. [kg]
EV015R+BAC	15	1/2	278	191	81	13	75	160	G1/4"	53	230	77	2.2
EV020R+BAC	20	3/4	285	203	75	14	75	162	G1/4"	57	232	77	2.5
EV025R+BAC	25	1	296	231	71	16	75	165	G1/4"	65	235	77	2.9
EV032R+BAC	32	1 1/4	324	254	68	19	75	168	G1/4"	71	238	77	3.8
EV040R+BAC	40	1 1/2	334	274	65	19	75	172	G1/4"	71	242	77	4.5
EV050R+BAC	50	2	341	284	69	22	75	177	G1/4"	80	247	77	6.0

Further documentation

- General notes for project planning
- Belimo Energy Valve web server manual
- Description of Data-Pool Values
- Description of Protocol Implementation Conformance Statement PICS